

WaterWatch2920 – Oil on Water Monitor



Partech Instruments is a specialist company providing analysers and instruments for monitoring and control in; wastewater, raw water, industrial effluent and surface water applications.

Whatever the application and whatever the location, Partech will supply an effective and efficient service and a support package tailored to suit the customer

Contamination of water courses by visible oil is a problem that requires fast, reliable detection to prevent damage to either the local environment or a treatment process. If oil is allowed to enter a river then wildlife can be harmed, if the oil then enters a drinking water plant damage can be caused to the processing system or more critically the quality of the drinking water can be affected.

Early warning of a problem allows remedial action to be taken either by automatically shutting down a process or control valve or by manual intervention. The monitor can also be connected to pollution prevention equipment such as oil dispersants or oil adsorbing mops and booms.

The floating sensor has a dual hull designed to channel any oil passing through the centre of the float so that it is presented to the detector. The infrared sensor emits light that is reflected from the surface, any oil that is present increases the amount of light reflected and this is then converted into the desired output signals.

The float is supplied with two fixing cables and a weight to keep it stationary and correctly orientated. In addition a range of mounting accessories can be offered to suit the individual requirements of each application. We are happy to offer advice on the best mounting system to your application.

Applications exist in power generation, manufacturing plants, oil and water separators and in roads and car park run off collection.



The WaterWatch2910 system uses a floating sensor to detect visible oil on water. The float can be deployed in any application where the surface of the water is relatively calm. The monitor will react rapidly to both partial and complete films of oil on the surface of the water.

The measuring system is extremely stable and needs only occasional validation to ensure reliable operation.

In addition to the alarm output the monitor provides an analogue signal proportional to the probability of oil being present. The higher the probability the more widespread the pollution. This enables tracking of the incident over time as well as providing an immediate callout alarm.

Associated Products

- WaterWatch2910 – Flow Cell Version
- WaterWatch2950 – Organic Pollution Monitor

WaterWatch2920 – Oil on Water Monitor

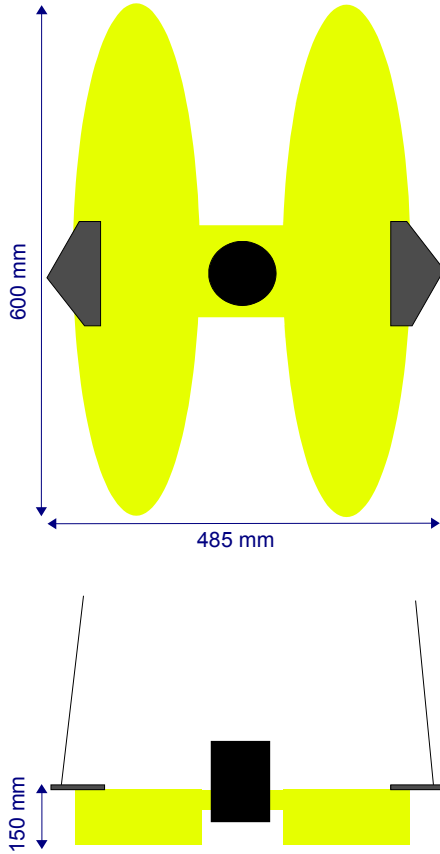

Physical - Monitor

Weight	2.2 kg
Dimensions (h x w x d)	222 x 214 x 92 mm
Enclosure Rating	IP65
Enclosure Material	ABS
Cable Entries	5 x M13 and 1 x M20
Cable Size	Max Conductor Cross Section 4 mm ²

Physical - Float

Weight	2.2 kg
Dimensions (h x w x l)	150 x 485 x 600 mm
Enclosure Rating	IP68
Enclosure Material	Fibre Glass Coated Float with Black Acetal Transmitter Housing

Environmental Data

Operating Temperature	0 to 60°C
Storage Temperature	-20 to 60°C
Location	Indoor or Outdoor

Power Supply

Voltage	115/230 VAC +10/-15% Field Selectable, 12/24 DC option
Power Consumption	11W

Analog Output

Number	1
Type	4-20 mA Isolated
Max Load Resistance	750 ohms

Relay Outputs and Set Points

No	2
Contacts	SPCO
Rating	5A @ 230 VAC, 5A@125 VDC
Type	High, Low or Fault
Adjustment	0-100% Sensor Range

Measurement Details

Response Time	0.2 to 120 seconds
---------------	--------------------

Serial Communications

RS232	Yes
Modbus	Pending
Profibus	Pending

User Interface

Display	4 Digit Red LED display for process variable 2 Line LCD display for Configuration and Operation via 5 Button Membrane Keypad
Setup	% Probability of Oil Presence

Software

Remote Programming	No
--------------------	----

Mounting

Monitor	Surface
Transducer	Float Mounted with 2 Stainless Steel restraining cables

Approvals

EMC Standard	EN50082-1 (1994) Residential, Commercial, Light Industry
EMC Directive	89/336/EEC
Low Voltage Directive	73/23/EEC

Part Numbers

201890	WaterWatch2920 – Monitor Visible Oil on Water
201900	WaterWatch2920 – Monitor Visible Oil on Water with datalogging
201910	WaterWatch2920 – Sensor Visible Oil on Water



Publication No: 184520 Rev 02
The company reserves the right to alter the specification without prior notice. E&OE



Introduction

Manual Conventions

All dimensions stated in this manual are in millimetres unless otherwise stated.

The manual has been written on the basis that the user has a basic knowledge of instrumentation and an understanding of the type of measurement being made.

Training in the use of the WaterWatch2920 Analysers can be provided, please contact Partech for further information.

Model Variations

This manual covers one variation of the WaterWatch2900 Series:

WaterWatch2920 – Visible Oil – Floating Sensor

Measurement Overview

The monitor detects the presence of an oil film on the surface of a watercourse using the principle of reflectance. An infra-red light beam is reflected by an oil sheen. This signal is processed and provides the output to the instrument. The sensor is supported on a float, which ensures the distance between sensor and water is maintained

Operation and Maintenance

Calibration

The instrument is calibrated by creating an oil film in a suitable test tank. The instrument is calibrated at zero with a clean water surface and 100% with a continuous oil sheen. This manual describes the procedure for calibration.

Maintenance Requirements

Maintenance is limited to cleaning the float and the surface of the optical sensor.

Service Requirements

No routine service is required.

Operational Limitations

Temperature

Upper and lower limits of temperature during storage and operation are limited. Upper limit is restricted to 60°C. At low temperatures the limit of operation is 0°C with the practical limitation being ice formation in the sample.

Maximum Levels

The system is designed to detect thin layers of oil on water as a visible sheen. The instrument is not suitable for use when the oil film is thick.

Operating Principle

Overview

The instrument comprises a floating sensor and associated transmitter. Combined together these make up a complete monitoring system that provides local display, alarms and re-transmitted analogue value of the percentage probability of an oil slick. The sensor is floated on a suitable sample surface, which is representative of the water supply likely to suffer contamination. The transmitter is mounted on a suitable wallboard and connects to the sensor using a 4-way cable.

Visible Oil Detection

The presence of any form of oil in the feed water to a water treatment plant is unacceptable and may lead to contamination of the final treated water. Although rare, pollution of raw water feeds can occur, as the result of accidental spillage and in addition discharges to watercourses must be free from visible oil. The technique used in this instrument applies particularly to oil types that form a “mono-molecular” film or sheen on the surface of water. These oil types tend to be persistent and resist evaporation. Examples are diesel oil, heating oil, fuel oil, lubricating oil and hydraulic oil. WaterWatch2920 Oil on Water detector is designed as a combined transmitter and alarm system capable of detecting visible oil layers, which may form on the surface of a lagoon, culvert, interceptor or other watercourse.

Floating Sensor

The sensor is designed to float on a calm water surface that is representative of the watercourse to be monitored.

The careful design of the culvert or lagoon being monitored is very important. The water should flow beneath the sensor whilst maintaining a calm surface. There is software included in the transmitter to allow for some surface disturbance.

The optical system combines with the electronic circuits located in the sealed sensor package. This sensor is supported on a float, which makes sure the correct distance between optical sensors and water surface is maintained. The float is positioned on the water surface to be monitored and moored in position. The electronics within the sensor conditions the signal and provides a nominal 4-20 mA loop signal, the current loop is calibrated in the main transmitter software so the absolute values from the sensor are not critical. Typically 12mA represents clean water and 20mA or greater represents a complete oil layer. Power to operate the sensor is derived from the transmitter and is a nominal 12 volts DC.

→ Oil Probability Function

In order to determine the presence of a layer of oil the instrument has been programmed to look at a series of readings over a short time period and generates a probability that there is an oil layer present. This is displayed as “% Probability Oil on Water”. This function has been designed specifically for the WaterWatch2920 Oil on Water measuring system and results in a technique that protects against spurious alarms generated by surface disturbance and high levels of suspended solids. In addition, if debris should drift under the measurement sensor, this will not produce a visible oil response but an alternative alarm condition.

Power Supply

The WaterWatch2920 uses a mains power supply, either 115 or 230 VAC. The correct voltage is field selectable using a switch on the PCB. The low voltage supply for the sensor is taken from the transmitter. Power supply can be set for 230 or 110volt operation.